

DETAIL A
2:1

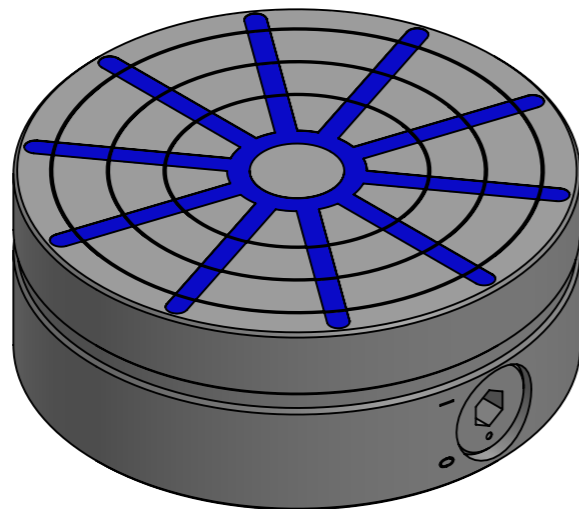
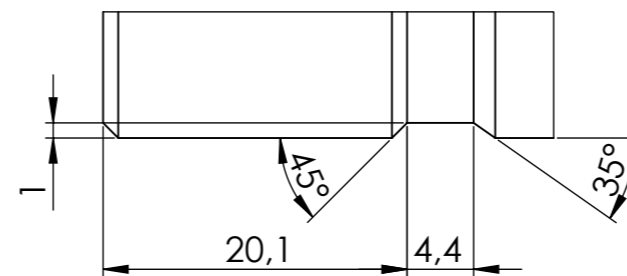

Schutzvermerk nach DIN ISO 16016 beachten! Nachdruck nur mit unserer Genehmigung! All rights reserved according to DIN ISO 16016! Reprint with our permission only!					tolerance	material:	weight: 7.50
					ISO 7168 M	drawing no.: 0024064	
				date	name	description: RS 15 Magnetrundfutter	
				drawn	12.03.2024	TW	
				appr.	12.03.2024	TW	
				 www.flraig-te.de		part no.:	sheet
						210315	1 / 2
rev.	change	date	name	scale: 1:1.5		Status: Freigegeben	A3

Maximum drill depth= 25mm

Maximum drill depth= 20mm

Maximum drill depth= Through

NO DRILL ZONES!!!

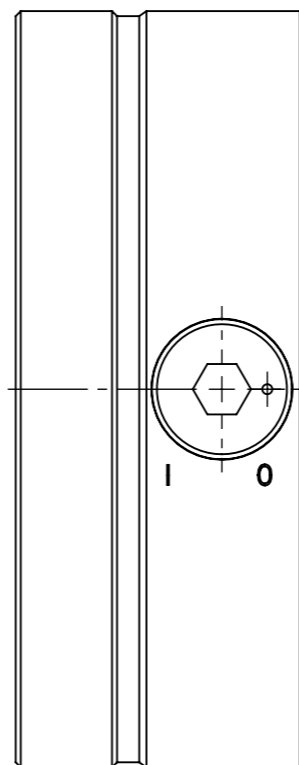
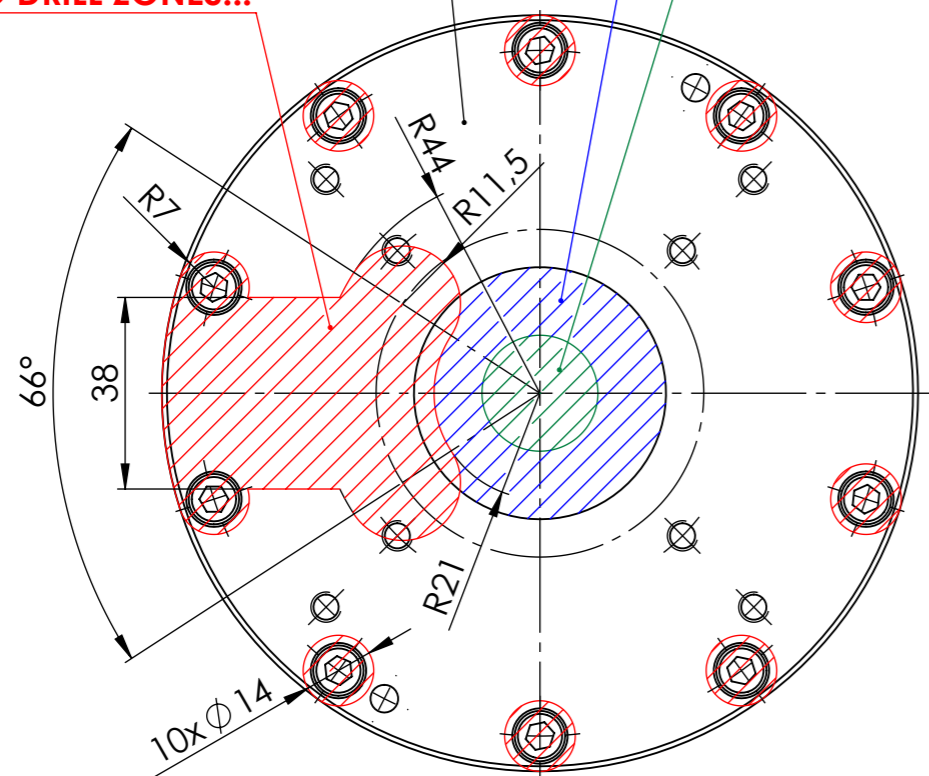

Maximum drill depth= 15mm

Maximum drill depth= Through

NO DRILL ZONES!!!

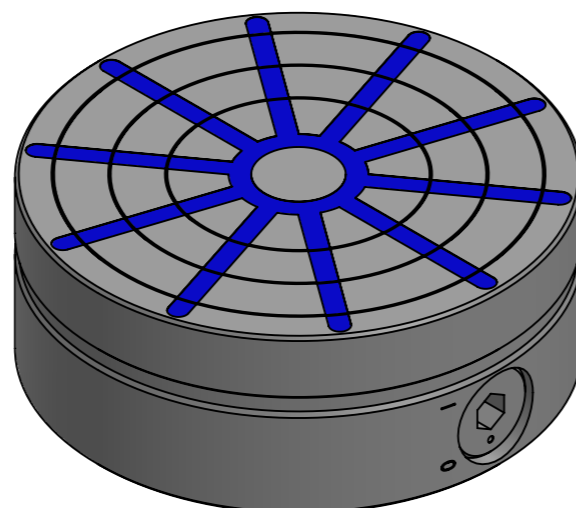
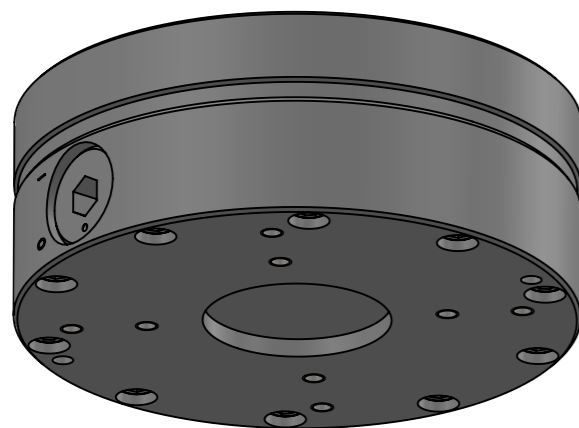
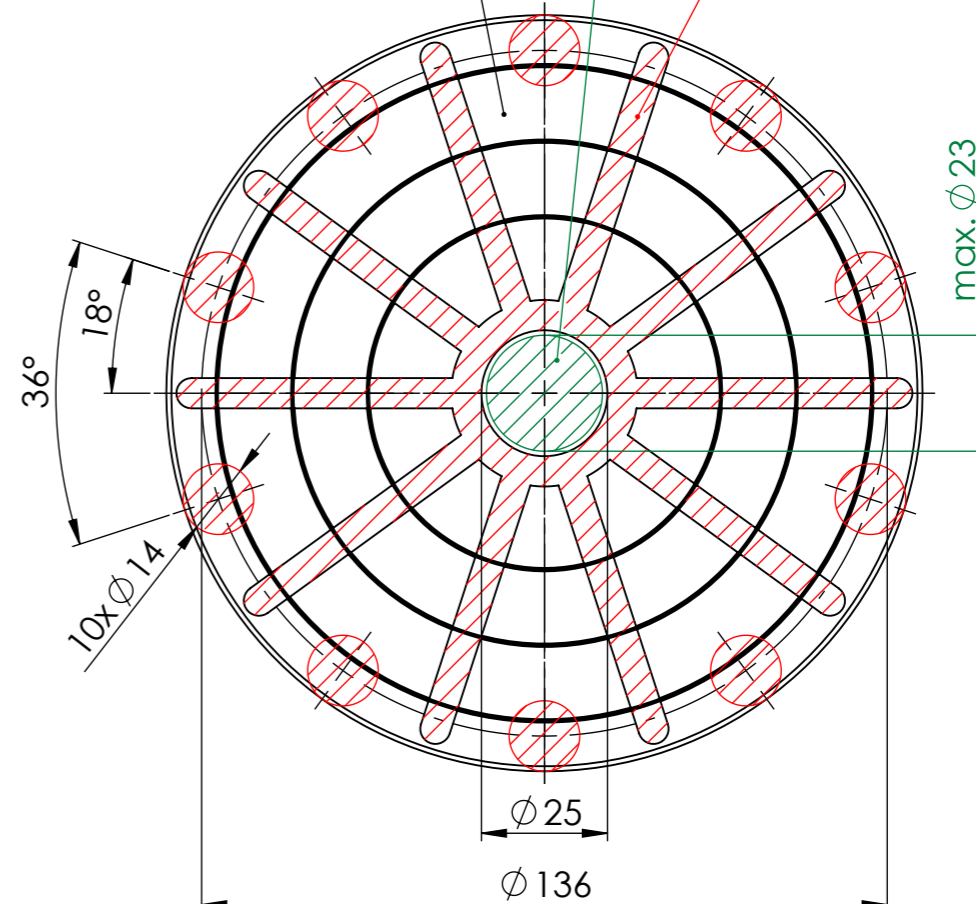

Schutzvermerk nach DIN ISO 16016 beachten! Nachdruck nur mit unserer Genehmigung!				3,2 / $\begin{matrix} -0,05 \\ -0,2 \end{matrix}$	tolerance	material:	weight: 7.50
All rights reserved according to DIN ISO 16016! Reprint with our permission only!					ISO 7168 M	drawing no.:	0024064
				date	name	description: RS 15 Magnetrundfutter	
				drawn	12.03.2024	TW	
				edit	12.04.2024		
				appr.	12.03.2024	TW	
				 www.flraig-te.de		part no.:	210315
						sheet	2 / 2
rev.	change	date	name	scale: 1:1.5		Status: Freigegeben	A3